

# Animated Tutorials

In this **Animated Tutorials** series, one will get a basic ideas of - how **tools** can be used to create drawings.

This tutorial will guide step by step to understand from very basic behavior of tools. In other word, it can be an **Animated User Manual**.

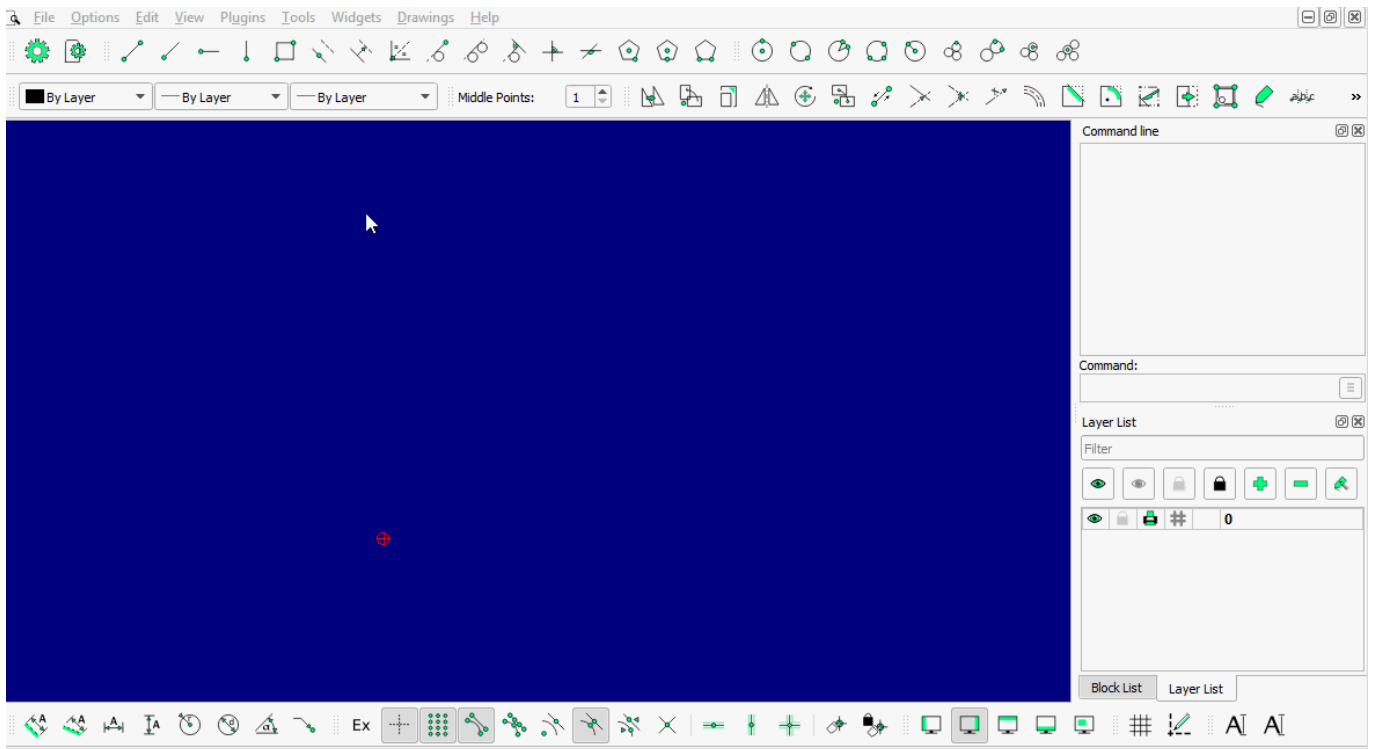

Contents of this Tutorial will follow as mentioned below.

- **Line**
- **Circle**
- **Modify**

## Contents Of Tools

Line	Circle	Modify
2 points	Center Point	Move / Copy
Angle	2 Points	Rotate
Horizontal	2 Points, Radius	Scale
Vertical	3 Points	Mirror
Rectangle	Center, Radius	Move and Rotate
Parallel through points	Tangential 2 Circles, 1 Point	Revert Direction
Parallel	Tangential, 2 Point	Trim
Bisector	Tangential 2 Circles, Radius	Trim Two
Tangent (P,C)	Tangential 3 Circles	Lengthen
Tangent (C,C)		Offset

Line	Circle	Modify
Tangent Orthogonal		Bevel
Orthogonal		Fillet
Relative Angle		Divide
Polygon (Cen, Cor)		Stretch
Polygon (Cen, Tan)		Properties
Polygon (Cor, Cor)		Attributes
		Explode text
		Explode
		Delete Selected

## Tool: LINE

### LINE: 2 Points

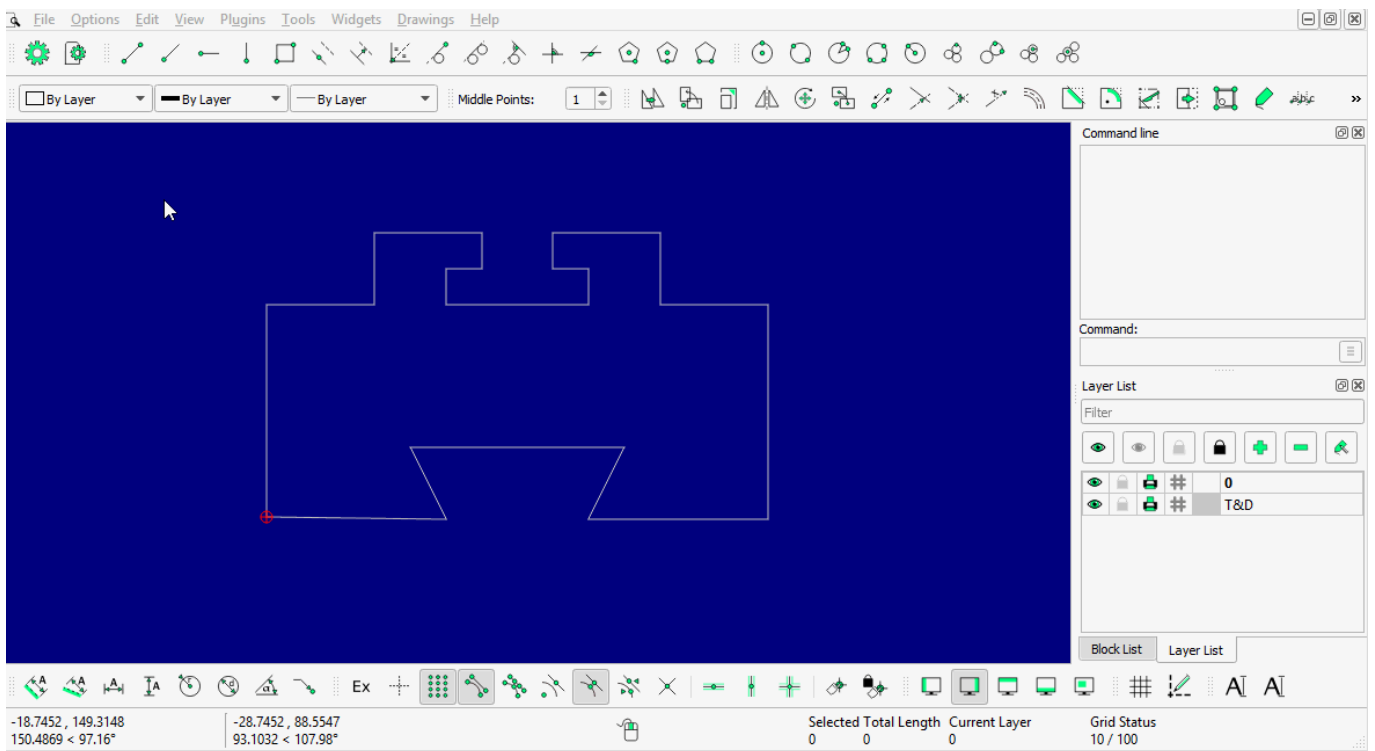

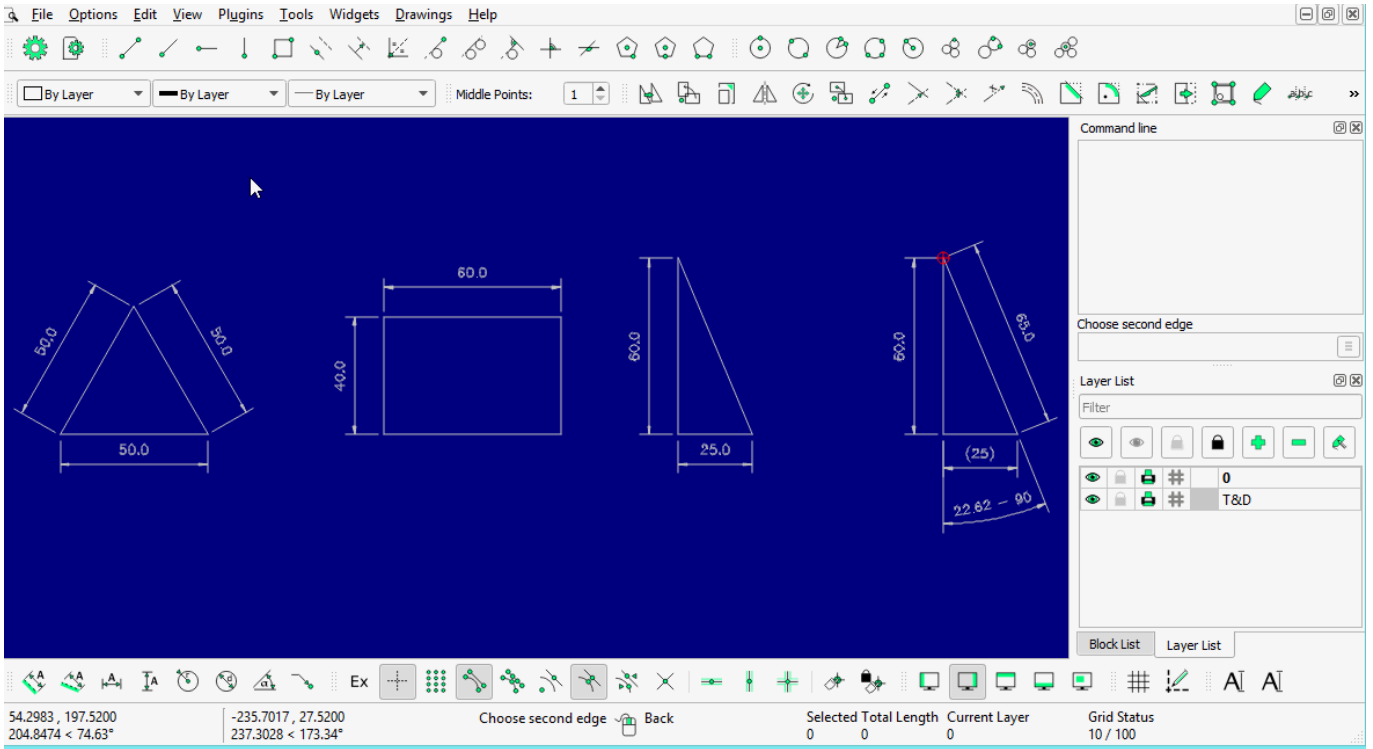

2 points with more detail...

### LINE: Angle

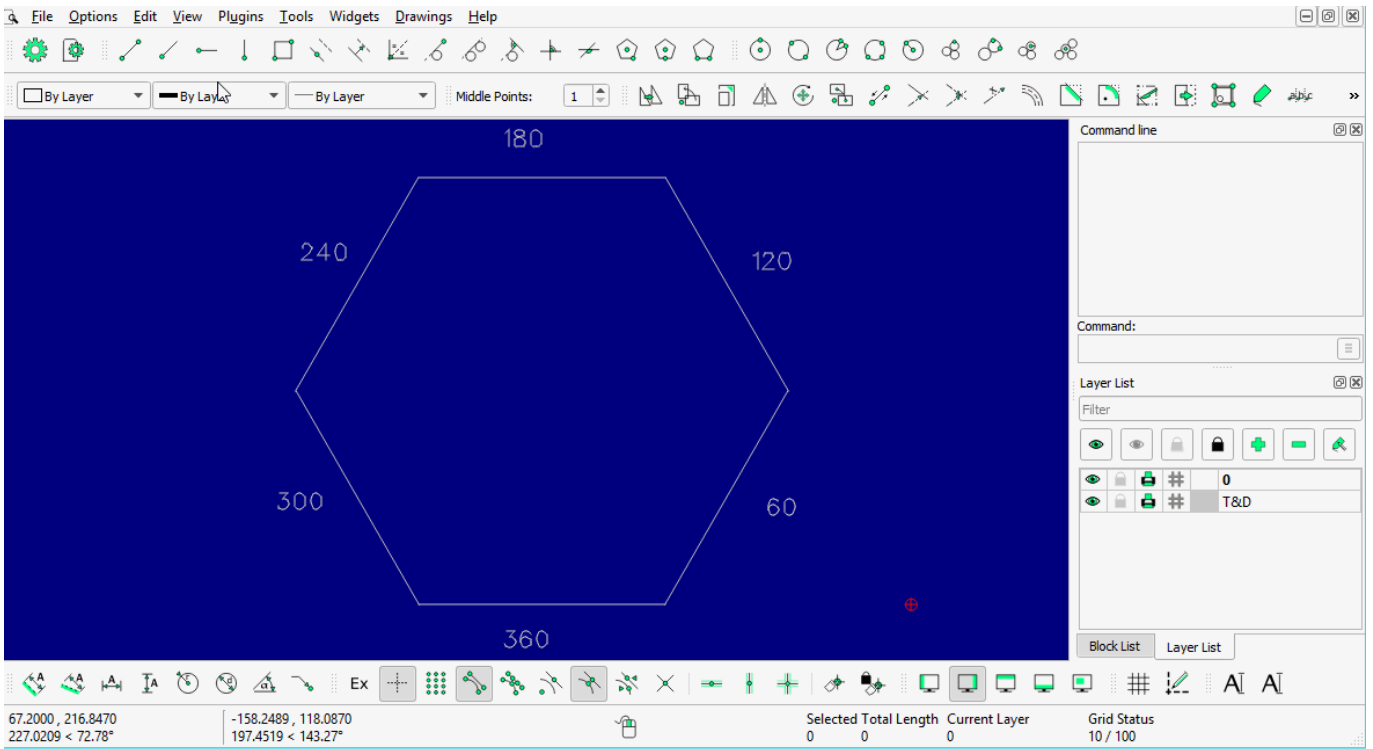

### LINE: Horizontal

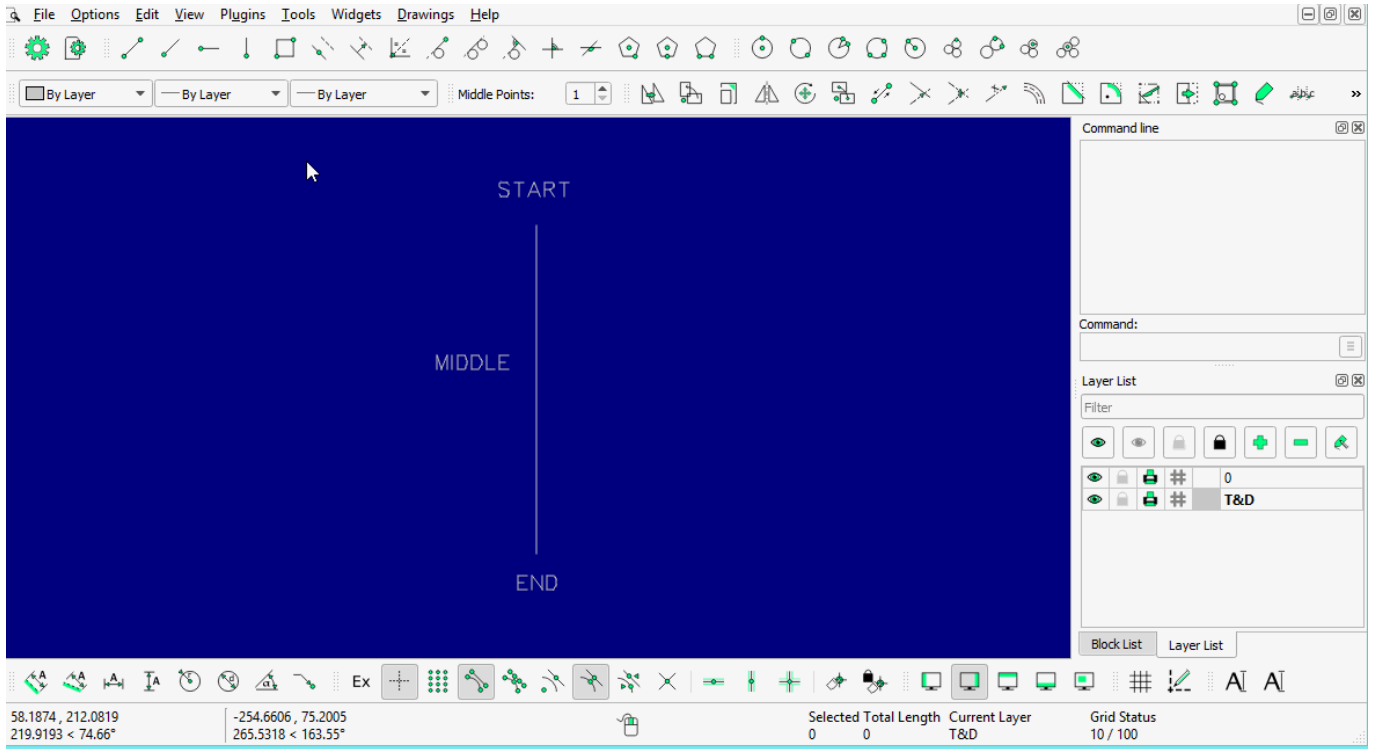

### LINE: Vertical

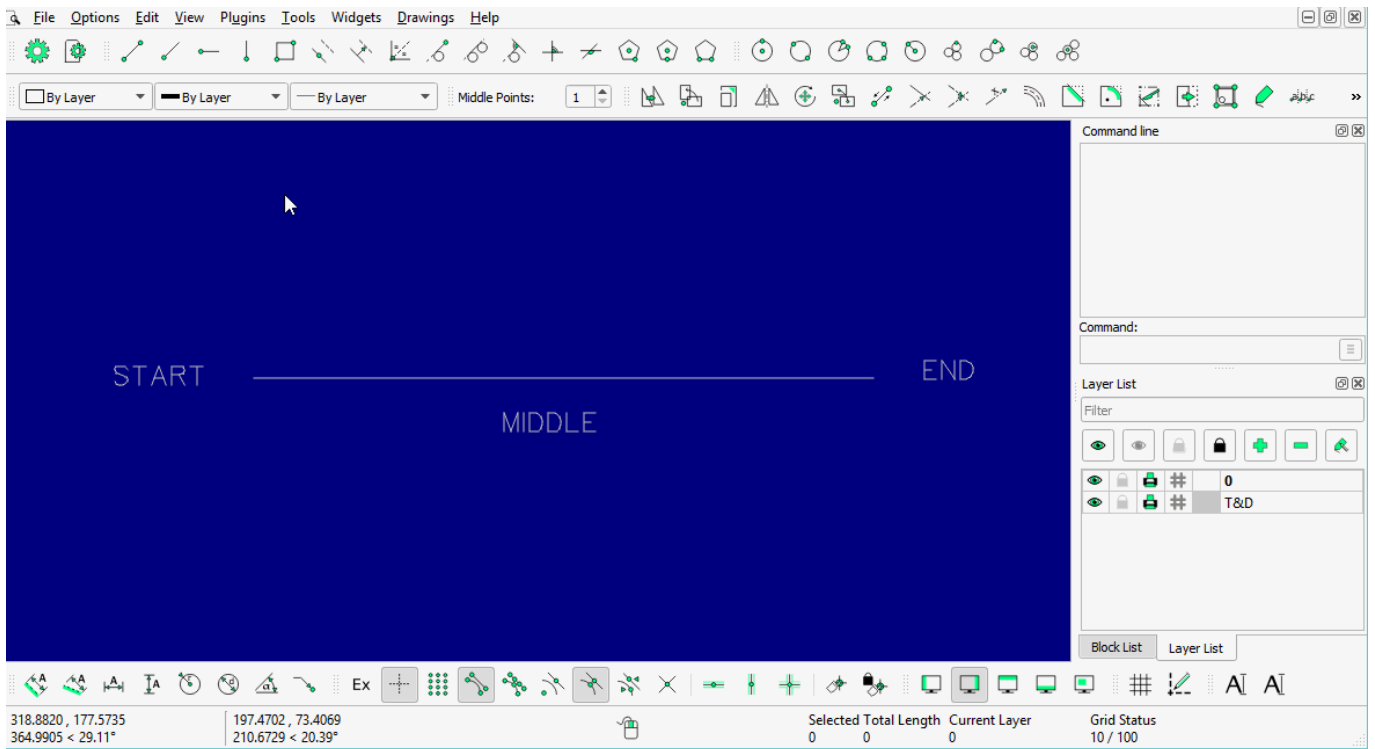

### LINE: Rectangle

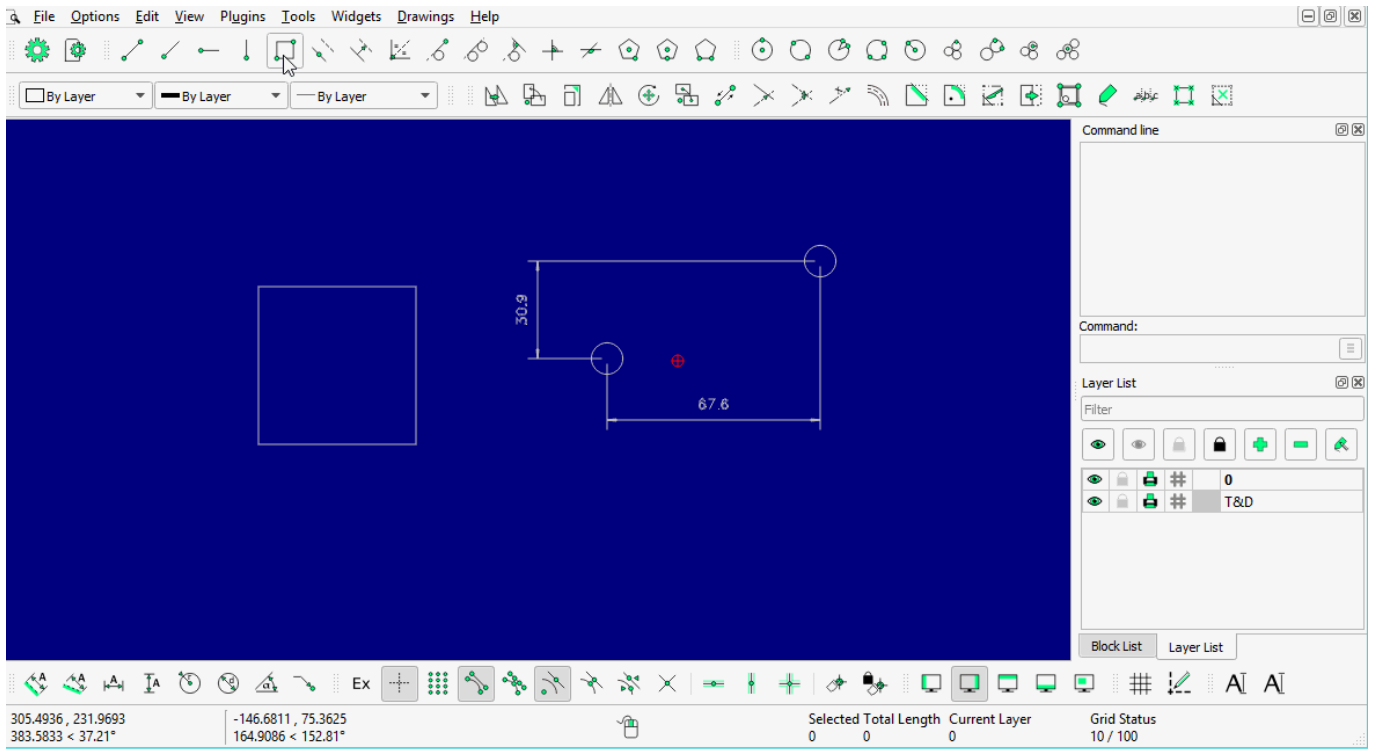

**LINE: Parallel through point**

**LINE: Parallel**

**LINE: Bisector**

**LINE: Tangent (P,C)**

**LINE: Tangent (C,C)**

**LINE: Tangent Orthogonal**

**LINE: Orthogonal**

**LINE: Relative Angle**

**LINE: Polygon [(Cen,Cor), (Cen,Tan), (Cor,Cor)]**

From:  
<https://dokuwiki.librecad.org/> - Wiki

Permanent link:  
<https://dokuwiki.librecad.org/doku.php/usage:animated?rev=1592141826>

Last update: 2020/06/14 13:37



